

PL

Advanced Solar Charge Controller

Simple, easy to read

User Guide

Read this before installing



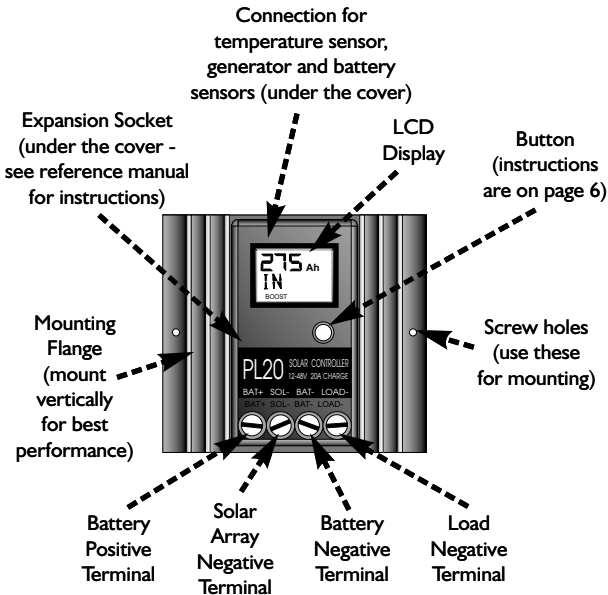

Screw wires into these terminals *tightly* as described on page 4.

Wiring instructions

4

Using the Menus

6

Choosing your settings

8

Monitoring your system

10

Where to set up your PL

Make sure you set up your PL:

- Vertically, where air can circulate around it;
- In a dry environment out of direct sunlight;
- Away from flammable gases or liquids;
- Away from spiders, wasps or other insects which might make nests in it.

Wiring instructions

Wires should be connected *tightly* as follows:

- Connect the fuse* on the positive (+) terminal of the battery to the “BAT +” terminal on your PL. (See diagram).
- Connect the positive (+) terminal of the solar panel to the fuse on the positive terminal of the battery.
- Connect the fuse on the negative (-) terminal of the battery to the “BAT -” terminal of the PL. The display panel of the PL should then start up.
- Connect the negative (-) terminal of the solar panel to the “SOL -” terminal of the PL.

The PL has a Load Disconnect feature (see page 13), which disconnects equipment powered by your battery (known as a “load”) if the voltage gets too low. To use this optional feature:

- Connect the fuse at the positive (+) terminal of your battery to the positive terminal of your load.
- Connect the negative terminal of your load to the “LOAD -” terminal of your PL. The load must draw less than 20A for the PL20, and less than 5A for the PL40. **(Note: Never connect batteries or inverters to this terminal!)**

You should now choose settings for your PL. See page 8.

*Australian Standards recommend that you connect an appropriate fuse to each terminal of the battery. Fuses are not supplied with the PL.

Warning: Never connect inverter or battery to “LOAD -” terminal.

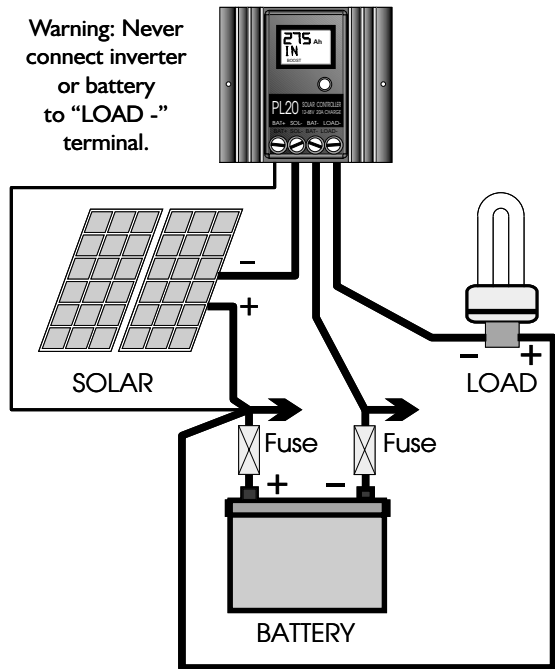

Using the Menus

Moving around

You can move around the menu system and change settings using the button on the front of the PL.

There are seven top-level menu items in the PL's menu system (BATV, CHRG, LOAD etc - see diagram opposite). Each menu item provides access to a sub-menu, and some of these sub-menus lead again to further sub-menus.

A **short-push** tells the PL to advance to the next menu or setting. To do a short push, press on the button on the front of the PL, and release it immediately.

A **long push** "selects", moving into a sub-menu or allowing you to change settings. To do a long push, press the button, holding it down until the menu changes (about one second).

Getting back

Wherever you are in the menu system, a series of short-pushes will bring you back to the top-level menus without changing any settings. There are two exceptions: when a number is flashing (you are already changing a setting - see page 8); and when you see the word "EXIT" (you're in "History" mode - see page 11).

→ Thin arrow = short push
 → Thick arrow = long push

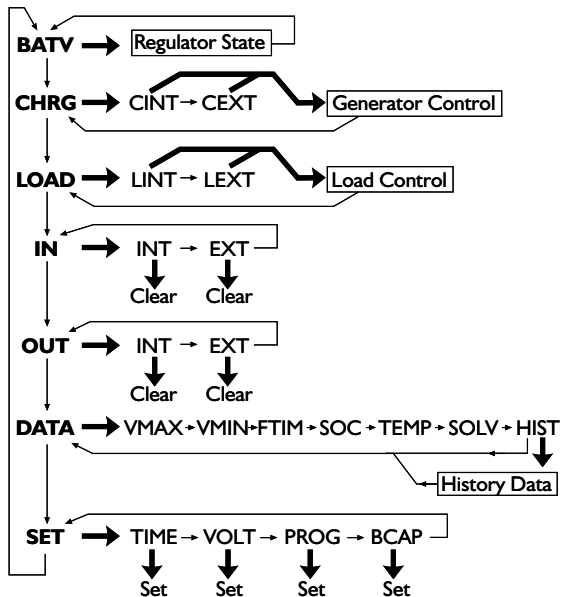

Choosing your settings

You must follow the procedure below to ensure that your PL will regulate correctly.

1. Set the Time

- Short-push until the display shows “SET”.
- Long-push once, and the display will show “TIME”.
- Long-push again, and the time will start flashing. (Note that the time is displayed in hours and tenths of hours. For example, “6.5” means 6:30am, and “13.1” means 1:06pm.)
- Short-push until the time shown is correct. If you reach 23.9, it will cycle back to 0.0 (midnight).
- When the time shown is correct, long-push to set it.

2. Set the System Voltage

- After setting the time, short-push to move from “TIME” to “VOLT”. Long-push, and the voltage will start flashing.
 - Short-push until the voltage is correct for your battery. If you reach 48V, it will cycle back to 12V.
- When the battery voltage is correct, long-push to set it.

3. Set your program

The PL comes with a number of pre-set programs, to make configuration easy for most installations.

- After setting the battery voltage, short-push to move from “VOLT” to “PROG”.
- Long-push once, and the program number will start flashing.
- Short-push to set your program:
 - PROG 0: Liquid Electrolyte Batteries, with Load Disconnect option (see page 13).
 - PROG 1: Gel batteries, with Load Disconnect option.
 - PROG 2: Liquid Electrolyte batteries with Light Controller option (see page 14).
 - PROG 3: Gel batteries with Light Controller option.
 - PROG 4: Customised setup. Choosing this program will require you to set a number of additional parameters. Details are described in the Reference Manual.
- When the program shown is correct, long-push to set it.

4. Set the Battery Capacity

- Short-push to move from “PROG” to “BCAP”.
- Long-push once, and the battery capacity will start flashing.
- Short-push to choose the correct battery capacity for your system in Ampere hours (Ah). (Large settings display in thousands - eg. 1600 Ah shows as “1.6”.) If you are unsure, check your battery manual or consult your battery supplier.
- Long-push to keep the chosen value.

Monitoring your system

The PL's advanced monitoring functions provide you with unparalleled information about your power setup. Here are some of the questions your PL can answer:

How full is the battery?

The voltage level of your battery is an approximate measure of how full it is, and is shown on the top-level "BATV" screen. Alternatively, SOC in the DATA sub-menu (long-push on DATA, then three short-pushes) uses the amp-hour data to provide an educated guess of the state of charge. (Warning: SOC will be useless if the PL is not measuring all the charge and discharge from the battery. For example, if an inverter is connected directly to the battery, an external shunt is needed so that the PL can include the inverter in its calculations.)

How much energy have I collected today?

The top-level IN screen shows how many Amp hours have been collected today.

How much energy have I used today?

The top-level OUT screen shows how many Amp hours the load has used today.

What voltage did the battery reach?

VMAX shows today's maximum voltage; VMIN shows today's minimum voltage. Both are in the DATA sub-menu.

What time did the battery finish charging today?

The FTIM screen in the DATA sub-menu shows the time the PL finished bulk charging and entered the "float" state (see p12).

Are components working correctly?

An optional temperature sensor can be connected to your PL to improve regulation. If this sensor is installed, the battery temperature is shown on the TEMP screen in the DATA sub-menu. To test your solar array, SOLV in the DATA menu shows the open-circuit voltage the solar array is generating.

How do today's figures compare with past figures?

The information described above is stored in your PL for the previous 30 days. To retrieve this history, a long-push on HIST in the DATA sub-menu will open the HIST sub-menu.

From the DAY 1 screen, short-pushes will cycle through yesterday's information. A long-push moves to DAY 2 (2 days ago), then DAY 3, etc. A long-push on EXIT puts you back in the DATA sub-menu.

The Battery Charging Process

When charging your battery, the PL moves automatically through the following charging sequence:

Boost phase - In this phase, all available charge is used to charge the battery as quickly as possible. When the battery is charging in the Boost phase, the “Boost” indicator appears on the PL’s screen.

Absorption phase - The battery is nearly full. To avoid excess gassing, the charge current is now adjusted to keep the battery voltage constant.

Float phase - The battery is fully charged, so the PL now monitors the battery and keeps it full. If the battery voltage drops below a pre-set point, the battery will move back to the Boost phase automatically.

To increase battery life, the PL will occasionally move into an additional phase called the **Equalisation phase**. This phase levels the charge between the different cells inside the battery by overcharging the battery for a short period.

The PL moves through these phases automatically, but it is also possible to change the phase manually. A long-push on the **BATV** menu will show the current charging phase. Subsequent long-pushes will move the PL into the next phase in the cycle.

The Load Disconnect Option

Load Disconnect is a feature of the PL which helps avoid battery damage by preventing the load from excessively draining the battery. You do not have to use this feature - the PL will still regulate effectively without it.

Load Disconnect works by turning the load off when the battery voltage falls below a pre-set point for a period of time. This feature is designed *not* to trigger if the battery voltage drops for just a few moments (for example, because a motor has just been turned on).

Once the battery has recharged to a safe level, the load will automatically switch on again.

To use Load Disconnect, you need to connect your load to the regulator as described on page 4, and you should also ensure that you have chosen a program where the Load Control feature is activated - see page 9.

Note - NEVER connect batteries or inverters to the LOAD terminal of the PL. They will cause heavy current flow which will damage the regulator.

The Light Controller Function

The Light Controller is an additional optional function of the PL. It can be used to switch lights on during darkness..

When it starts getting dark and the voltage from the solar array drops, the Light Controller function will switch on power to the PL's LOAD terminal. If you have connected lights to the PL's LOAD terminal, the PL will switch on the lights at dusk and switch them off at dawn.

To use the Light Controller option, choose a PL program which enables this function, as described on page 9. You should then wire your lights to the LOAD terminal as described in parts (e) and (f) on page 4.

Note that if the battery's voltage falls below a pre-set level, the Load Disconnect function will protect the battery by switching off the lights even if it is dark. The Load Disconnect function is described on page 13.

Other Advanced Features

The PL has a number of advanced features and optional components which are described in the Reference Manual. These include:

- Plug-in shunts which allow the PL to incorporate an inverter or backup generator in its calculations
- Generator control
- Second battery control
- An alarm triggered by low battery voltage
- Extra controls for larger systems, via an expansion board
- Interface for remote control via a computer and a modem
- Shunt regulation and pulse width modulation options
- Battery temperature sensor
- Remote control

For more information, consult the Reference Manual or the following web page on the internet:

<http://plasmatronics.taz.net.au>

Plasmatronics

<http://plasmatronics.taz.net.au>
42 Bell St Fitzroy 3065 Victoria Australia